

10104997 - X 0 C - X 0 X L F

6-COLUMN DIFFERENTIAL SIGNAL

LEAD-FREE DESIGNATION ONLY WITH APPLICABLE PLATING CODES

LETTER	PERFORMANCE-BASED PLATING (SEE NOTE 2)	
	TARGET APPLICATION	LEAD FREE (LF)
B	TELCORDIA CO	NO
C	TELCORDIA UE	NO
D	TELCORDIA CO	YES
E	TELCORDIA UE	YES

NUMBER	PIN STYLE, HEIGHT
0	STANDARD GUIDE PIN MACHINED, 31.6mm

MODULE DESCRIPTION	LETTER DESIGNATION REPRESENTED IN DASH NUMBER										BASE MODULE
LEFT POLARIZING GUIDANCE MODULE (SEE SHEET 3)	J	A	B	C	D	E	F	G	H		
RIGHT POLARIZING GUIDANCE MODULE (SEE SHEET 4)	Y	P	Q	R	S	T	U	V	W		
OPEN MODULE (TWO WALL) (SEE SHEET 2)	0 (ZERO)										
LEFT WALL MODULE (SEE SHEET 5)	L										
RIGHT WALL MODULE (SEE SHEET 6)	M										
FOUR WALL MODULE (SEE SHEET 7)	1										

NUMBER	CONTACT MATING WIPE LENGTH		COMPLIANT PIN DRILL SIZE
	SIGNAL	WIDE GROUND	
1	2	4	Ø0.55 [0.0217"]
2	3	4	Ø0.55 [0.0217"]
3	2	4	Ø0.45 [0.0177"]
4	3	4	Ø0.45 [0.0177"]
5	2	3	Ø0.55 [0.0217"]
6	3	3	Ø0.55 [0.0217"]
7	2	3	Ø0.45 [0.0177"]
8	3	3	Ø0.45 [0.0177"]

	GROUNDED	UNGROUNDED
FINISHED	Ø2.35-2.55	Ø2.35-2.55
PAD	Ø5.50	N/A
PLATED	YES	NO
DRILL (mm/in)	2.58 / .1015	2.44 / .096

SCREW P/N	DESCRIPTION	BOARD THICKNESS
10091790-002LF	#2-56 X .375" PHILLIPS PANHEAD W/SQ CONICAL WASHER	1.60 - 5.00
10091790-003LF	#2-56 X .500" PHILLIPS PANHEAD W/SQ CONICAL WASHER	5.00 - 10.00

spec ref	SEE NOTES	dr	Kok-Hoe Lee	2010/06/23	projection	MM	size	A2	scale	4:1	
tolerance std	ASME Y14.5	eng	Sandar Soe	2014/10/02	chr	-	ecn no	ELX-S-18843-1	rel level	Released	
surface	linear	0.X	±0.2	0.XX	±0.10	0.XXX	±0.050	angular	0°	±°	
ASME Y14.5	angular	0°	±°	www.fci.com		cat. no.	SEE P/N TREE	Product - Customer Drw	sheet 1 of 8	rev	E

Copyright FCI. FCI

OPEN (2-WALL) MODULE

SEE NOTE 8

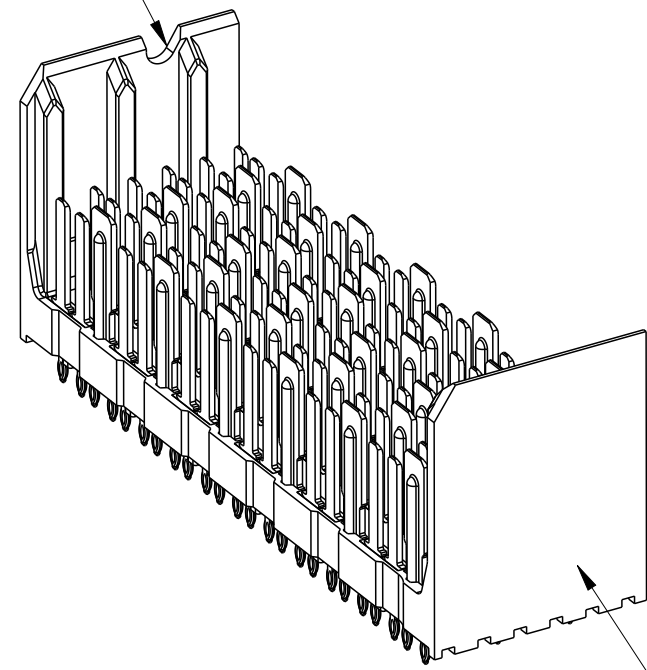

SEE NOTE 5

POSN A1 (11.05 MAX)

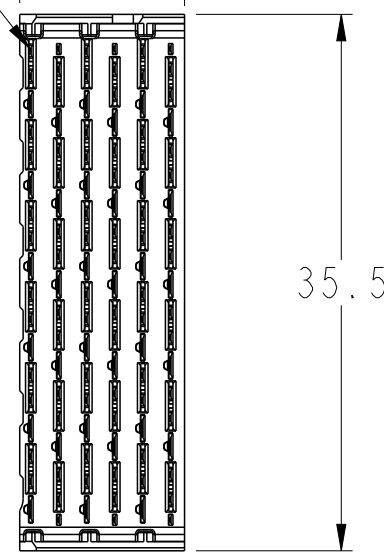

35.5

- 6.2 (4MM WIPE WIDE GROUNDS)
- 5.2 (3MM WIPE WIDE GROUNDS)
- 5.2 (3MM SMALL END GROUNDS)
- 5.2 (3MM WIPE SIGNALS)
- 4.2 (2MM WIPE SIGNALS)

(SEE P/N TREE FOR ALL COMBINATIONS AVAILABLE)

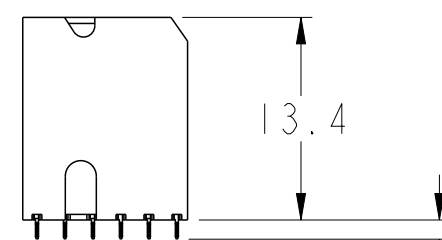
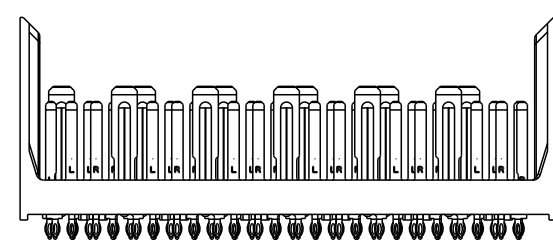
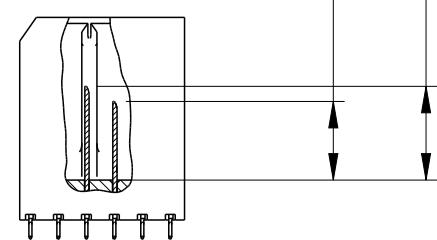

TAIL LENGTH
SEE NOTE 12

2.54
TO TOP SURFACE
OF DAUGHTERCARD

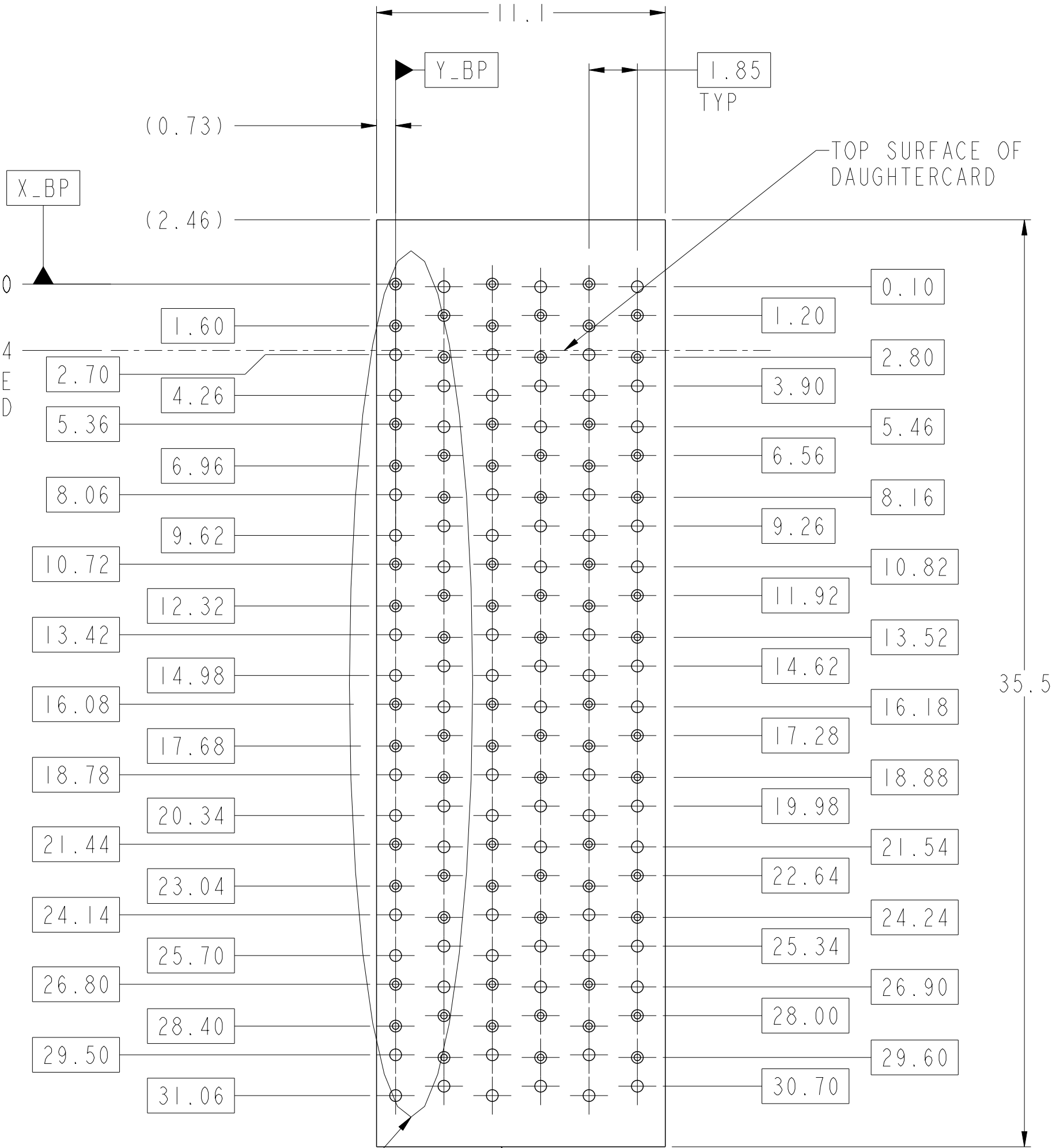

SEE DETAIL A
(SHEET 8)

NOMINAL MODULE OUTLINE

PCB HOLE PATTERN
COMPONENT SIDE
SCALE 6:1

spec ref	SEE NOTES	dr	Kok-Hoe Lee	2010/06/23	projection	MM	size	A2	scale	4:1	
tolerance std	TOLERANCES UNLESS OTHERWISE SPECIFIED	eng	Sandar Soe	2014/10/02			ecn no	ELX-S-18843-1	rel level	Released	
ASME Y14.5		chr		2014/12/10							product family
surface	linear	0.X	±0.2		TITLE MODULE ASSEMBLY VERTICAL HEADER, 6-COLUMN, 6-PAIR	dwg no 10104997	rev E				
		0.XX	±0.10					cat. no.	SEE P/N TREE	Product - Customer Drw	sheet 2 of 8
ASME Y14.5	angular	0°	±°								



Copyright FCI.

LEFT POLARIZING/GUIDE MODULE

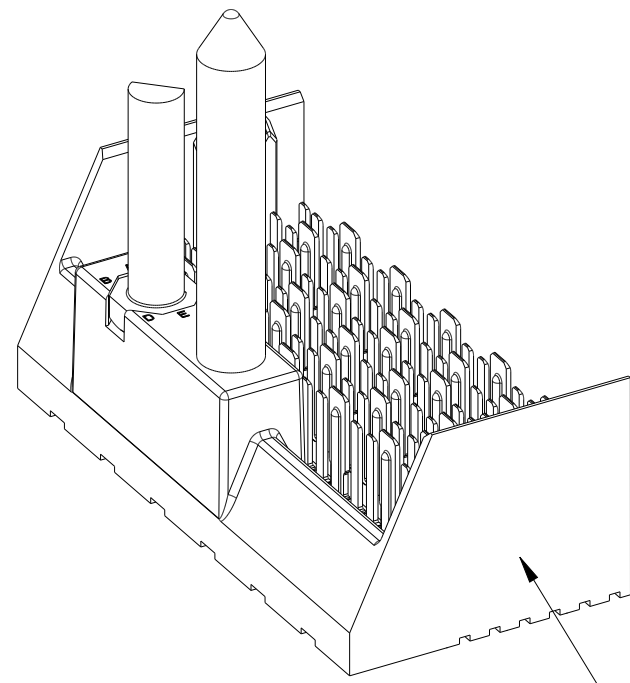

SEE NOTE 5

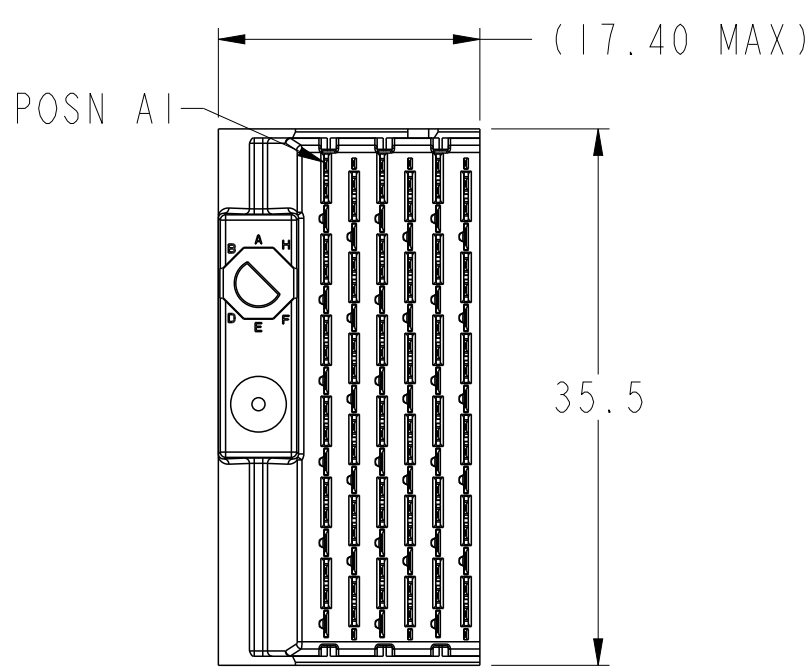

- 6.2 (4MM WIPE WIDE GROUNDS)
 - 5.2 (3MM WIPE WIDE GROUNDS)
 - 5.2 (3MM SMALL END GROUNDS)
 - 5.2 (3MM WIPE SIGNALS)
 - 4.2 (2MM WIPE SIGNALS)
- (SEE P/N TREE FOR ALL COMBINATIONS AVAILABLE)

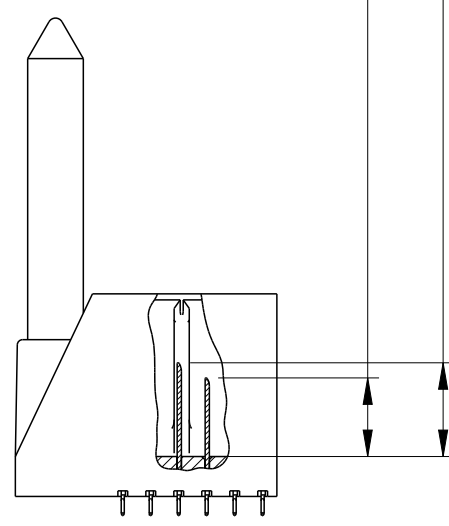

OPTIONAL KEYING PIN
(SEE P/N TREE)

GUIDE PIN

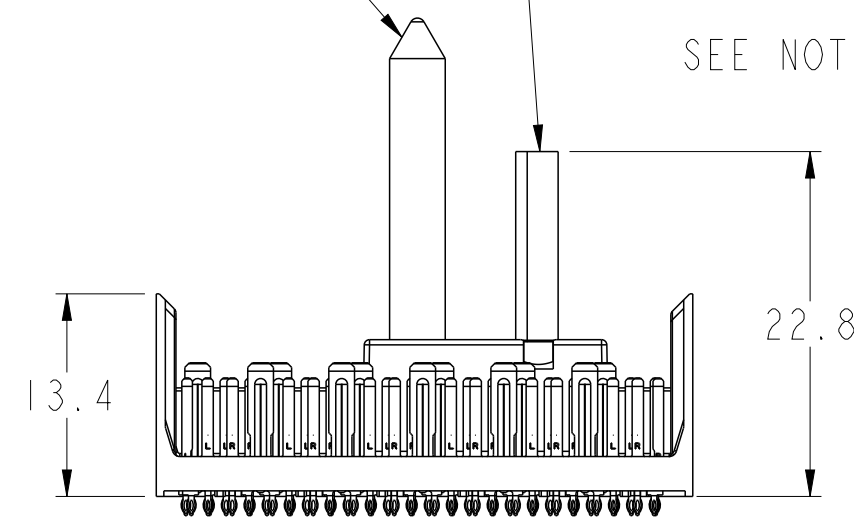

SEE NOTE 8

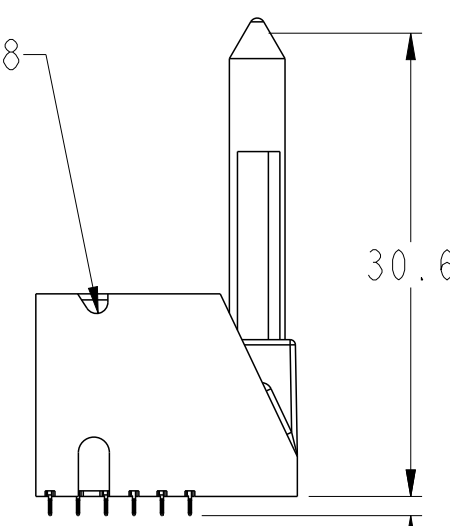

TAIL LENGTH
SEE NOTE 12

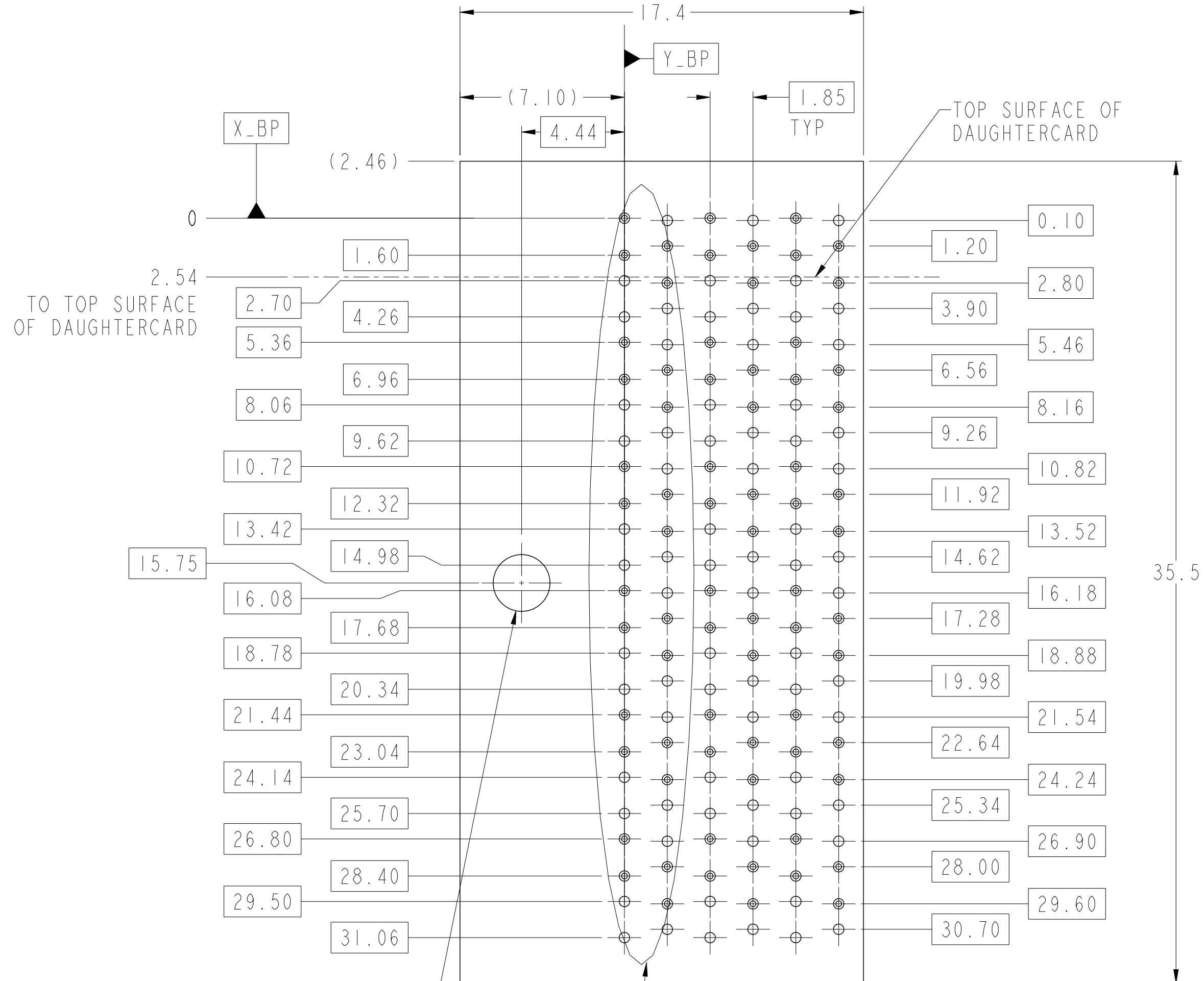

\varnothing	0.10	X_BP	Y_BP
---------------	------	------	------

SEE NOTE 11 & TABLE 1

SEE DETAIL A
(SHEET 8)

PCB HOLE PATTERN
COMPONENT SIDE
SCALE 6:1

spec ref	SEE NOTES	dr	Kok-Hoe Lee	2010/06/23	projection	MM	size	A2	scale	4:1
tolerance std	ASME Y14.5	eng	Sandar Soe	2014/10/02	chr	-	ecn no	ELX-S-18843-1	rel level	Released
surface	✓	appr	Chen-Hong Tan	2014/12/10	product family	XCode	cat. no.	SEE P/N TREE	Product - Customer Drw	sheet 3 of 8
linear	0.X ±0.2 0.XX ±0.10 0.XXX ±0.050	angular	0° ±°			TITLE MODULE ASSEMBLY VERTICAL HEADER, 6-COLUMN, 6-PAIR	dwg no 10104997	rev E		

PDS: Rev :E

STATUS:Released

Printed: Dec 10, 2014

Copyright FCI. FCI

RIGHT POLARIZING/GUIDE MODULE

SEE NOTE 8

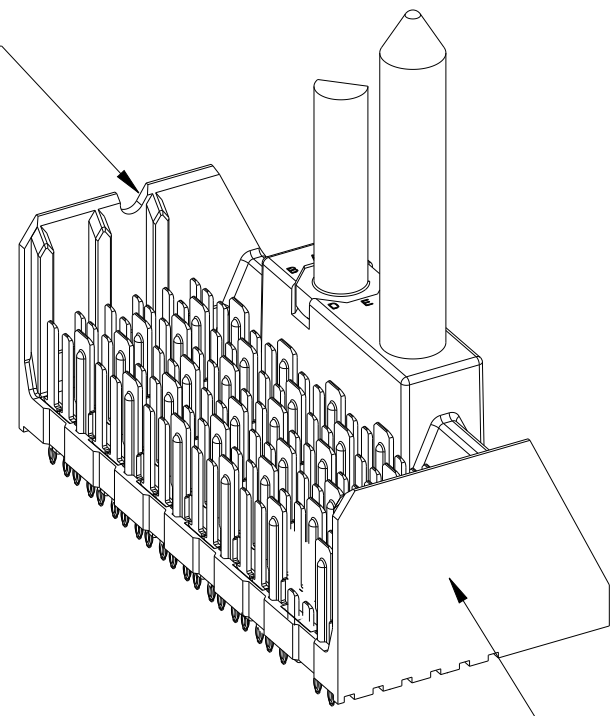

SEE NOTE 5

POSN A1 (17.50 MAX)

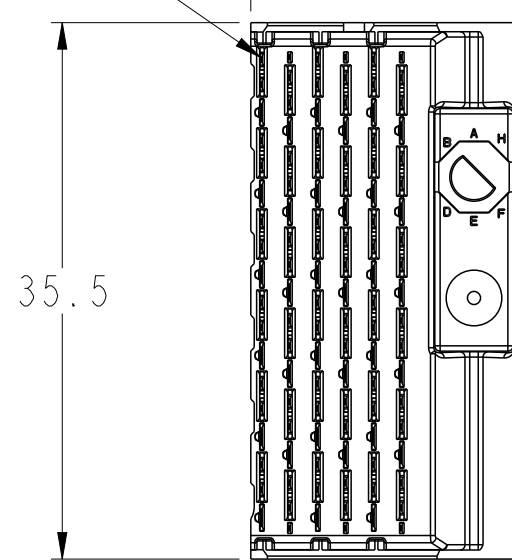

35.5

- 6.2 (4MM WIPE WIDE GROUNDS)
- 5.2 (3MM WIPE WIDE GROUNDS)
- 5.2 (3MM SMALL END GROUNDS)
- 5.2 (3MM WIPE SIGNALS)
- 4.2 (2MM WIPE SIGNALS)

(SEE P/N TREE FOR ALL COMBINATIONS AVAILABLE)

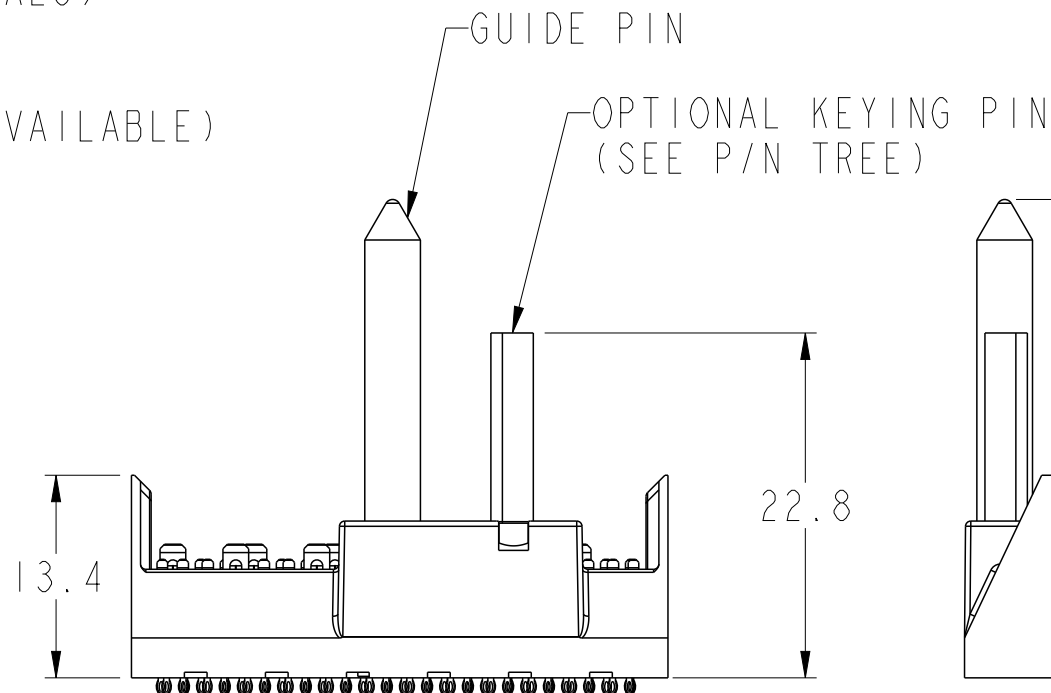
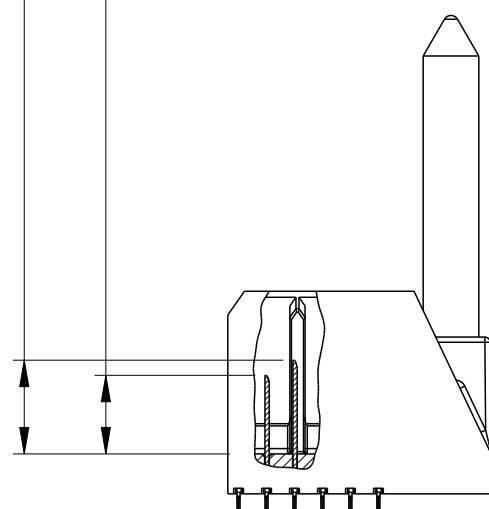

TAIL LENGTH SEE NOTE 12

2.54 TO TOP SURFACE OF DAUGHTERCARD

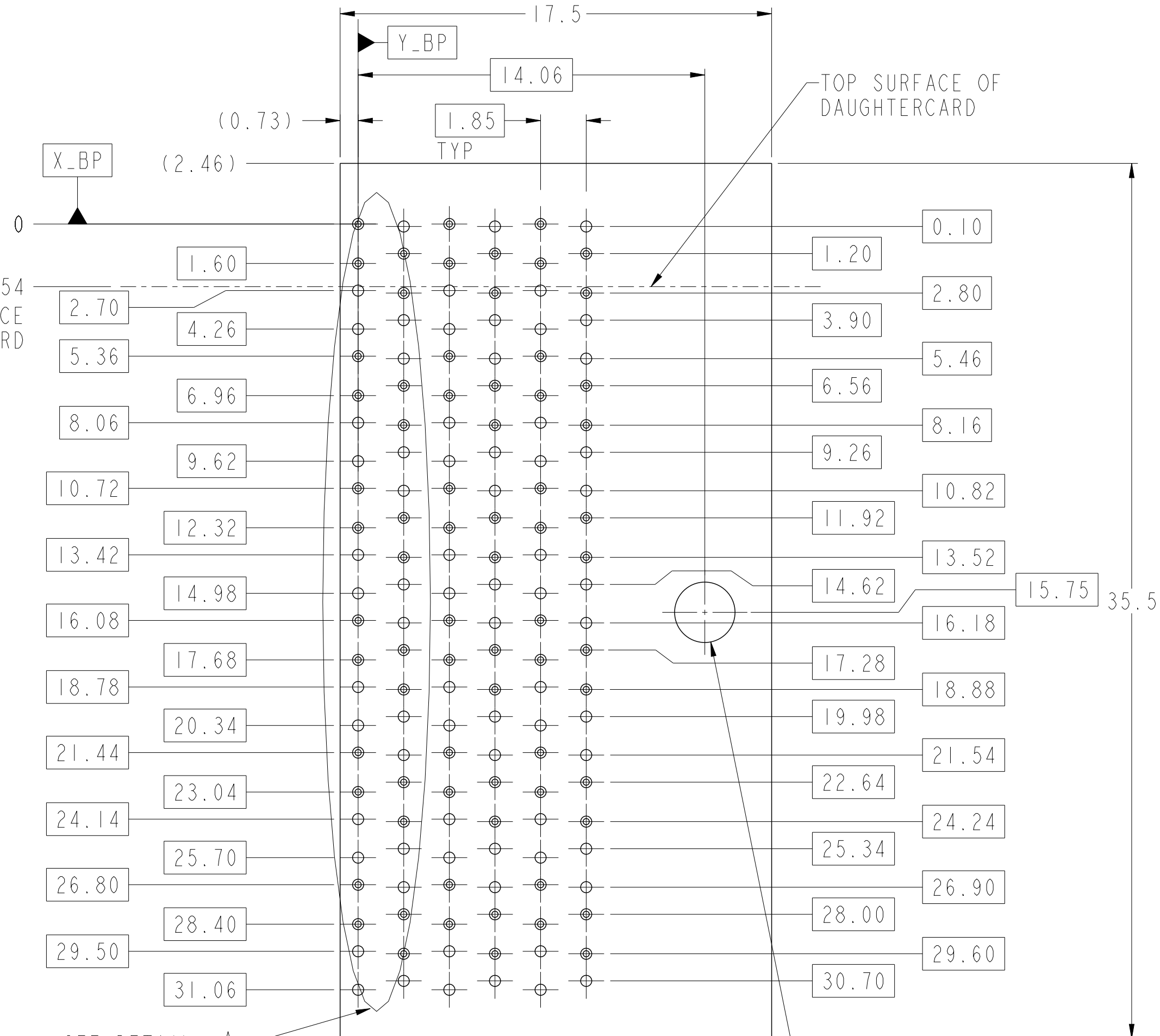

spec ref	SEE NOTES	dr	Kok-Hoe Lee	2010/06/23	projection	MM	size	A2	scale	4:1
tolerance std	ASME Y14.5	eng	Sandar Soe	2014/10/02	chr	-	ecn no	ELX-S-18843-1	rel level	Released
surface	linear	0.X	±0.2	0.XX	±0.10	0.XXX	±0.050	product family	XCode	rel level
ASME Y14.5	angular	0°	±°	FCJ		www.fci.com	cat. no.	SEE P/N TREE	Product - Customer Drw	sheet 4 of 8
TITLE		MODULE ASSEMBLY		VERTICAL HEADER, 6-COLUMN, 6-PAIR		dwg no	10104997		rev	E



Copyright FCI.

LEFT WALL MODULE

SEE NOTE 8

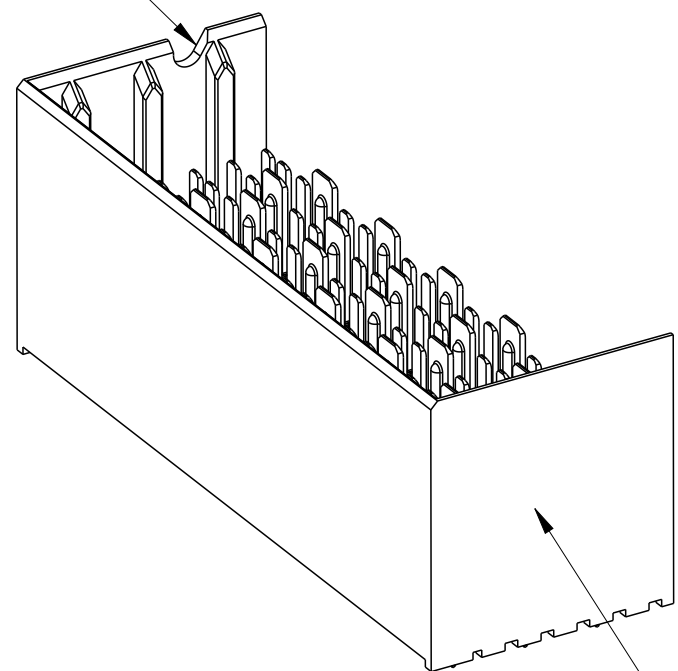

SEE NOTE 5

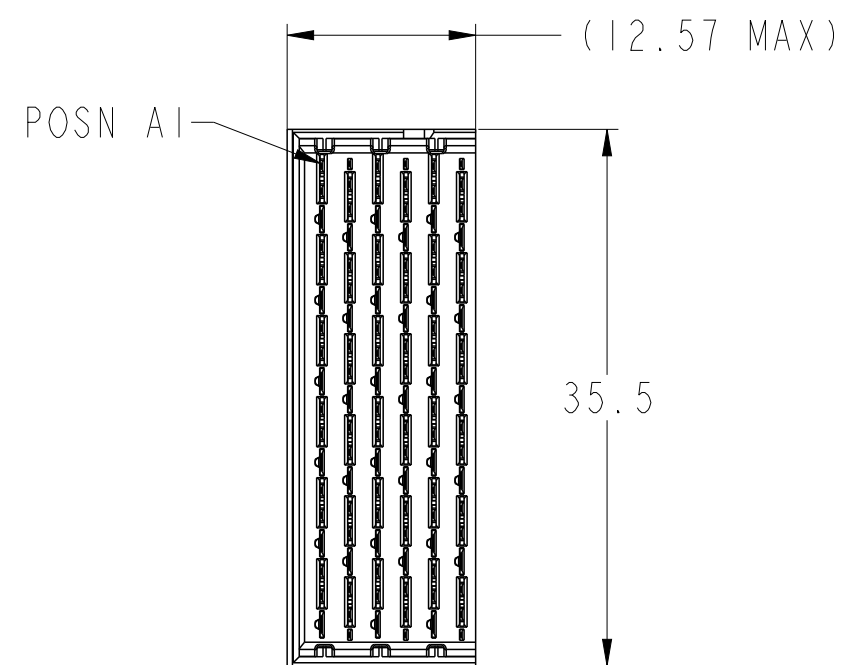

- 6.2 (4MM WIPE WIDE GROUNDS)
- 5.2 (3MM WIPE WIDE GROUNDS)
- 5.2 (3MM SMALL END GROUNDS)
- 5.2 (3MM WIPE SIGNALS)
- 4.2 (2MM WIPE SIGNALS)

(SEE P/N TREE FOR ALL COMBINATIONS AVAILABLE)

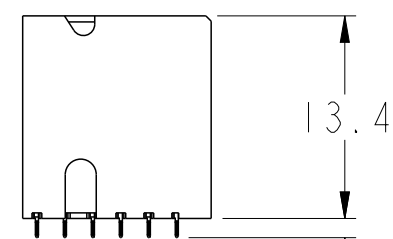
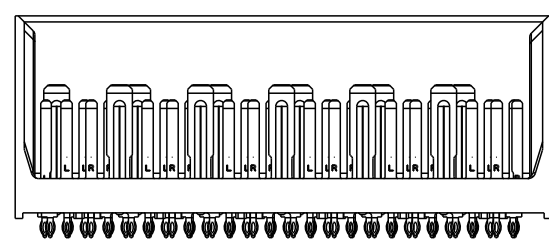
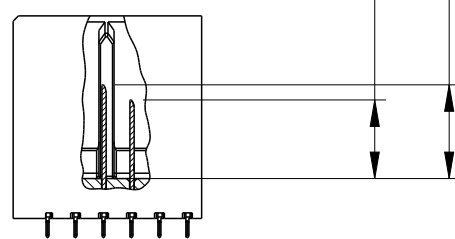

△ TAIL LENGTH
SEE NOTE 12

2.54
TO TOP SURFACE
OF DAUGHTERCARD

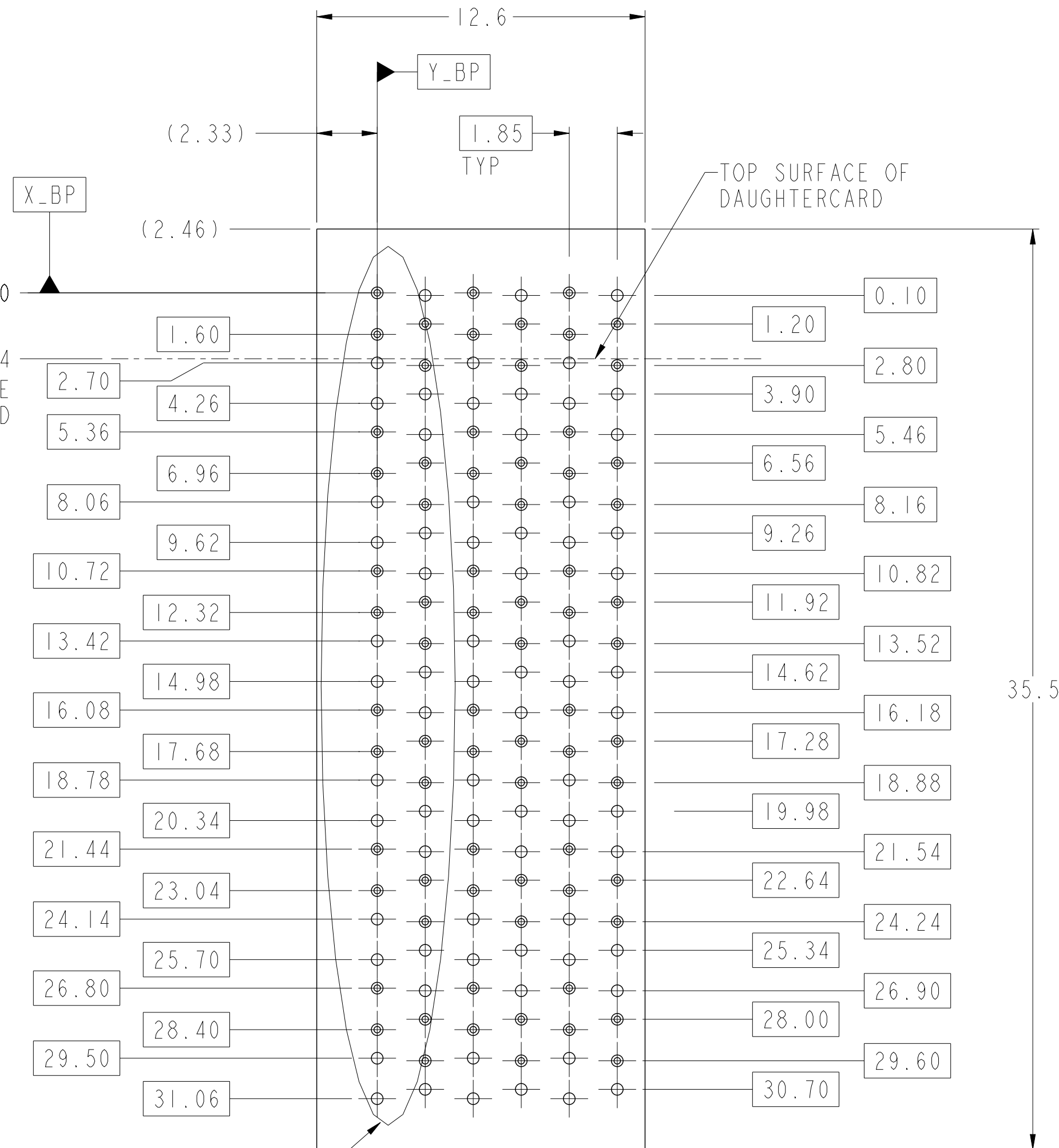

SEE DETAIL A
(SHEET 8)

NOMINAL MODULE OUTLINE
PCB HOLE PATTERN
COMPONENT SIDE
SCALE 6:1

spec ref	SEE NOTES	dr	Kok-Hoe Lee	2010/06/23	projection	MM	size	A2	scale	4:1
tolerance std	ASME Y14.5	eng	Sandar Soe	2014/10/02	chr	-	ecn no	ELX-S-18843-1	rel level	Released
surface	✓	appr	Chen-Hong Tan	2014/12/10	product family	XCode	cat. no.	SEE P/N TREE	Product - Customer Drw	sheet 5 of 8
linear	0.X ±0.2 0.XX ±0.10 0.XXX ±0.050	angular	0° ±°			TITLE MODULE ASSEMBLY VERTICAL HEADER, 6-COLUMN, 6-PAIR	dwg no 10104997	rev E		

RIGHT WALL MODULE

SEE NOTE 8

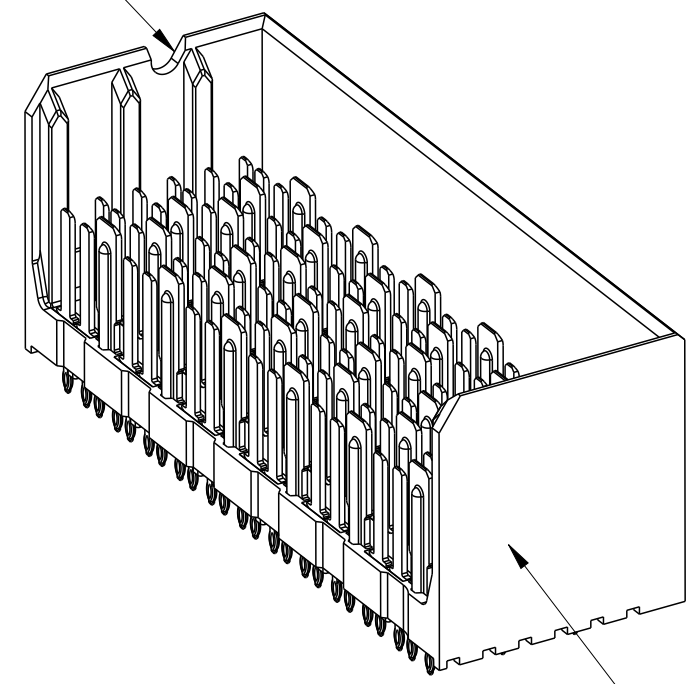

SEE NOTE 5

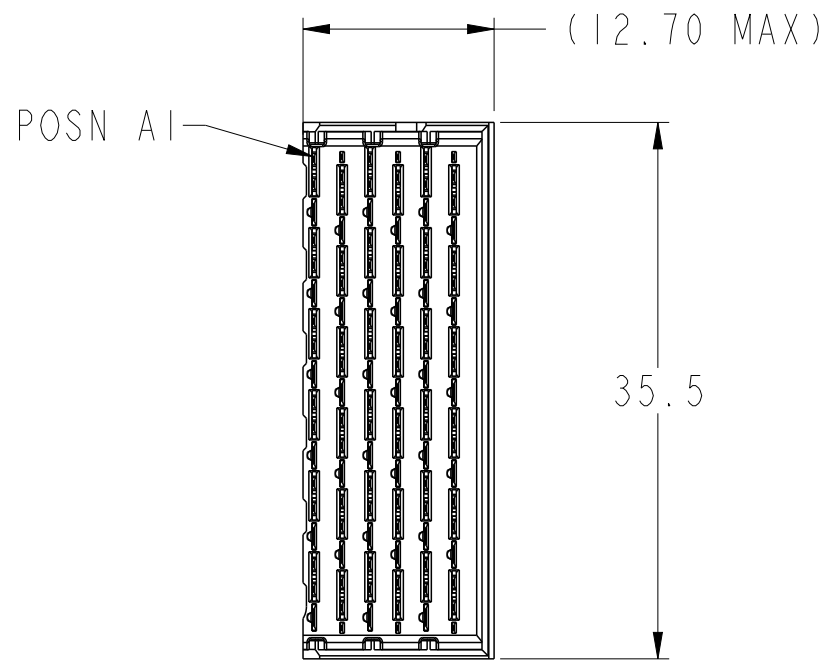

SCALE 2:1

- 6.2 (4MM WIPE WIDE GROUNDS)
- 5.2 (3MM WIPE WIDE GROUNDS)
- 5.2 (3MM SMALL END GROUNDS)
- 5.2 (3MM WIPE SIGNALS)
- 4.2 (2MM WIPE SIGNALS)

(SEE P/N TREE FOR ALL COMBINATIONS AVAILABLE)

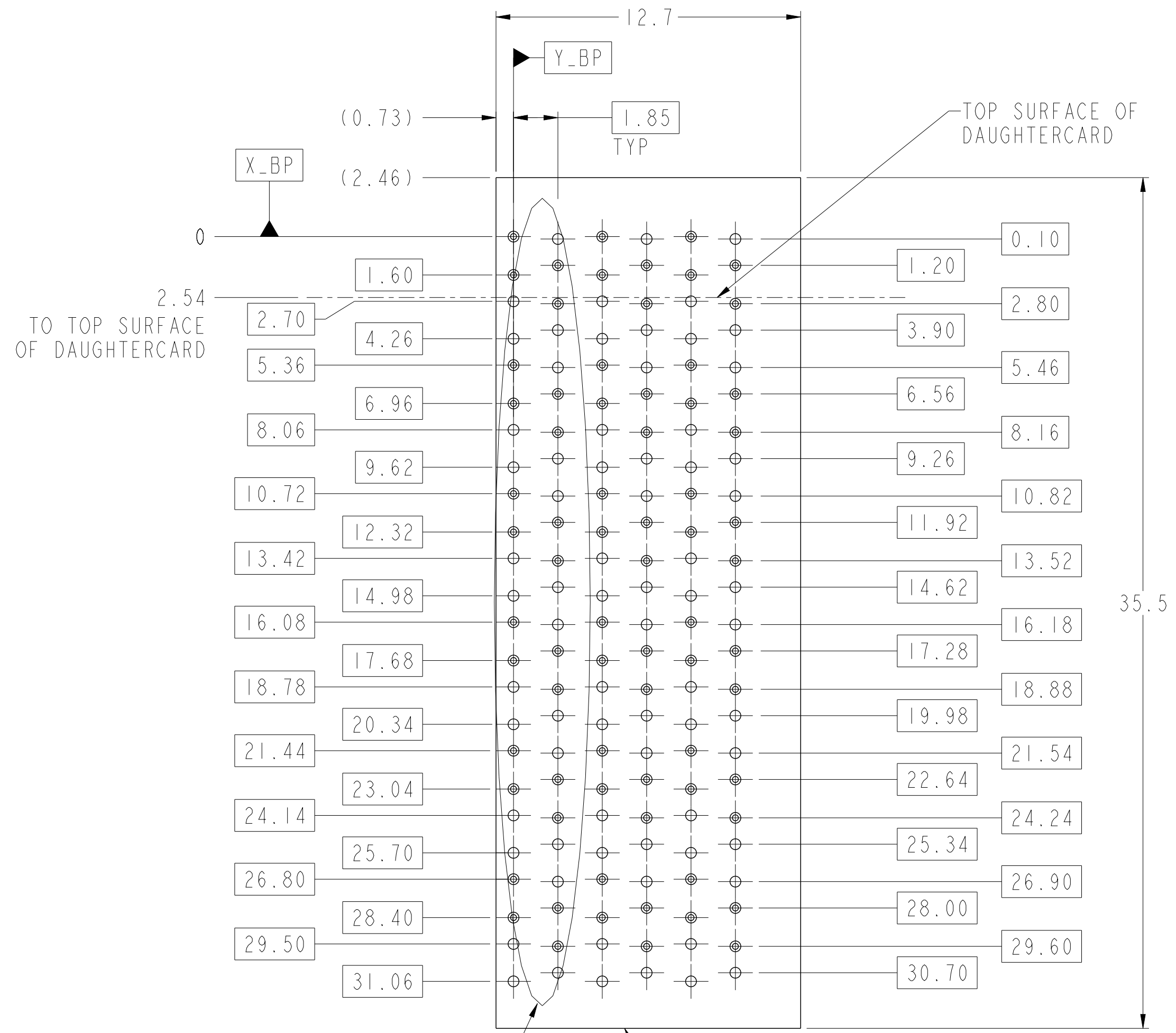
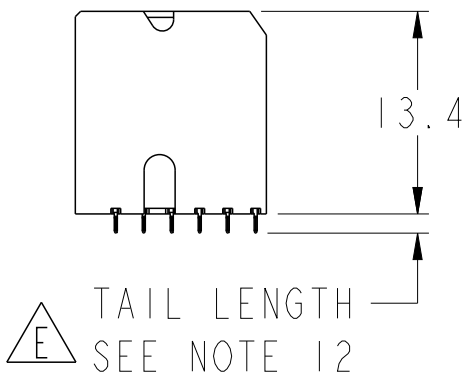
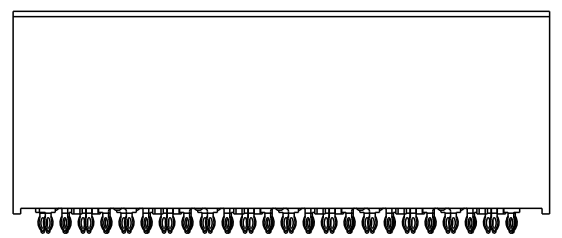
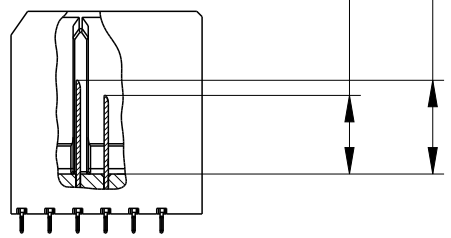

SEE DETAIL A (SHEET 8)

NOMINAL MODULE OUTLINE

PCB HOLE PATTERN
COMPONENT SIDE
SCALE 6:1

spec ref	SEE NOTES	dr	Kok-Hoe Lee	2010/06/23	projection	MM	size	A2	scale	4:1
tolerance std	ASME Y14.5	eng	Sandar Soe	2014/10/02	chr	-	ecn no	ELX-S-18843-1	rel level	Released
surface	✓	appr	Chen-Hong Tan	2014/12/10	product family	XCede	dwg no	10104997	rev	E
ASME Y14.5	linear	0.X	±0.2	0.XX	±0.10	0.XXX	±0.050	angular	0°	±°
		www.fci.com		cat. no.		SEE P/N TREE	Product - Customer Drw		sheet 6 of 8	

PDS: Rev :E

STATUS:Released

Printed: Dec 10, 2014



Copyright FCI.

FOUR WALL MODULE

SEE NOTE 8

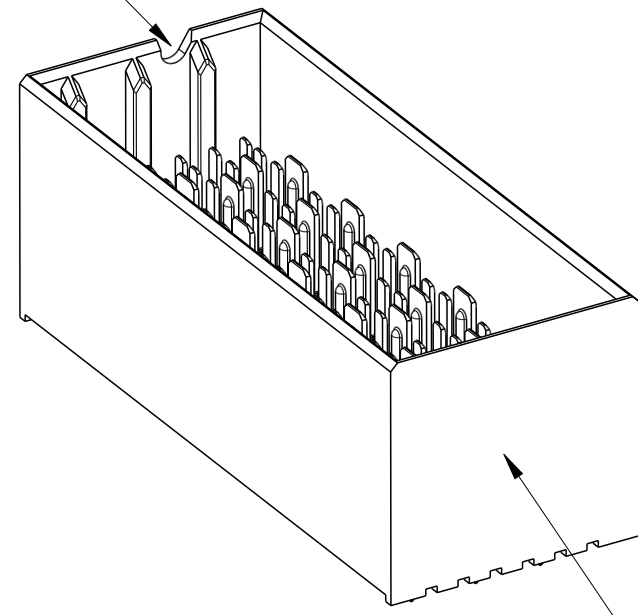

SEE NOTE 5

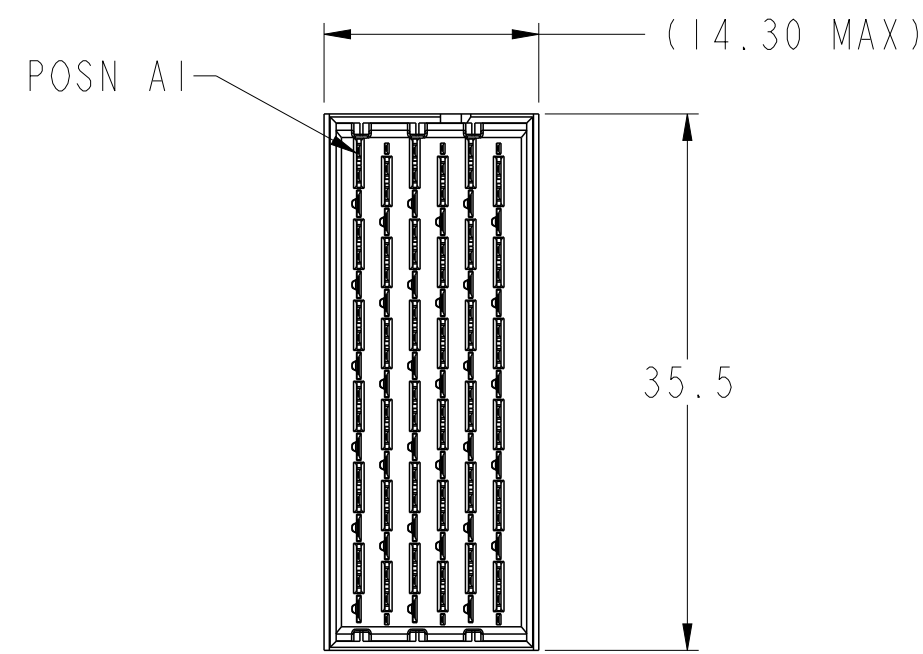

- 6.2 (4MM WIPE WIDE GROUNDS)
- 5.2 (3MM WIPE WIDE GROUNDS)
- 5.2 (3MM SMALL END GROUNDS)
- 5.2 (3MM WIPE SIGNALS)
- 4.2 (2MM WIPE SIGNALS)

(SEE P/N TREE FOR ALL COMBINATIONS AVAILABLE)

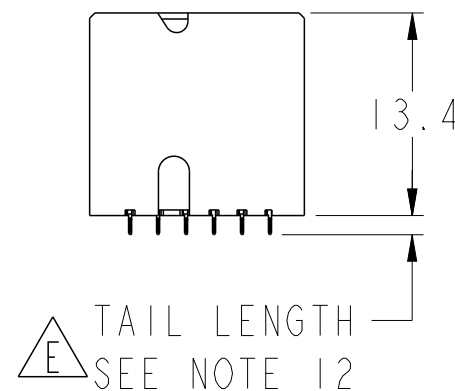
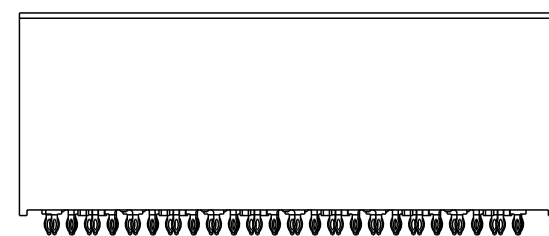
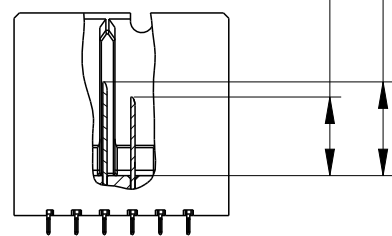

TAIL LENGTH SEE NOTE 12

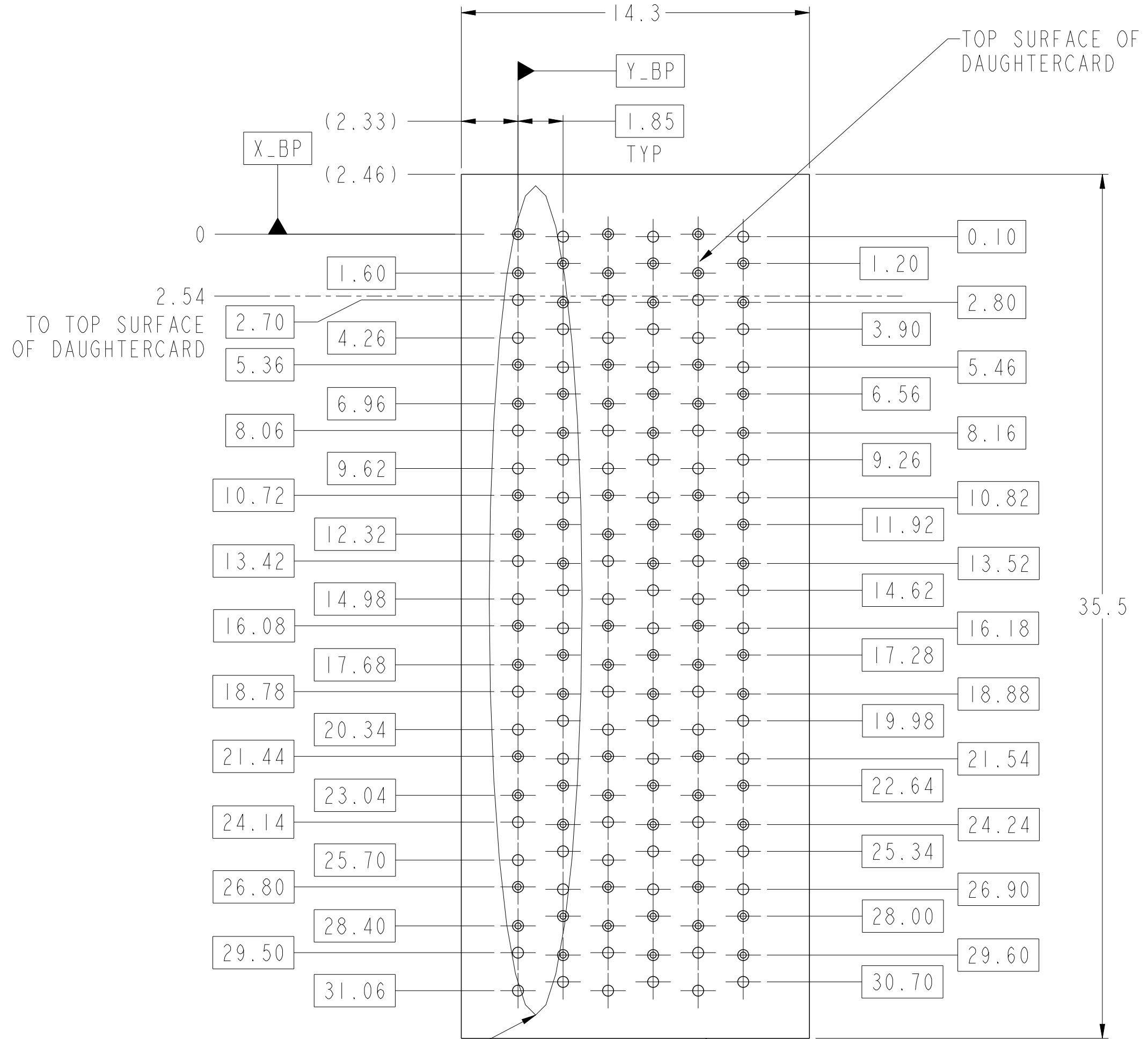

SEE DETAIL A (SHEET 8)

NOMINAL MODULE OUTLINE
PCB HOLE PATTERN
COMPONENT SIDE
SCALE 6:1

spec ref	SEE NOTES	dr	Kok-Hoe Lee	2010/06/23	projection	MM	size	A2	scale	4:1
tolerance std	ASME Y14.5	eng	Sandar Soe	2014/10/02	chr	-	ecn no	ELX-S-18843-1	rel level	Released
surface	✓	appr	Chen-Hong Tan	2014/12/10	product family	XCede	dwg no	10104997	rev	E
ASME Y14.5	linear	0.X	±0.2	0.XX	±0.10	0.XXX	±0.050	angular	0°	±°
		www.fci.com		cat. no.		SEE P/N TREE	Product - Customer Drw		sheet 7 of 8	

TABLE 3: PTH AND PAD SIZES WITH REFERENCE TO COMPLIANT PIN DRILL		
COMPLIANT PIN DRILL	PTH	PAD
Ø0.55 [0.0217"]	Ø0.45±0.05	Ø0.85
Ø0.45 [0.0177"]	Ø0.36±0.05	Ø0.75

REFER TABLE 3 FOR PTH, DRILL & PAD SIZES

⊕	Ø0.10	X_BP	Y_BP
---	-------	------	------

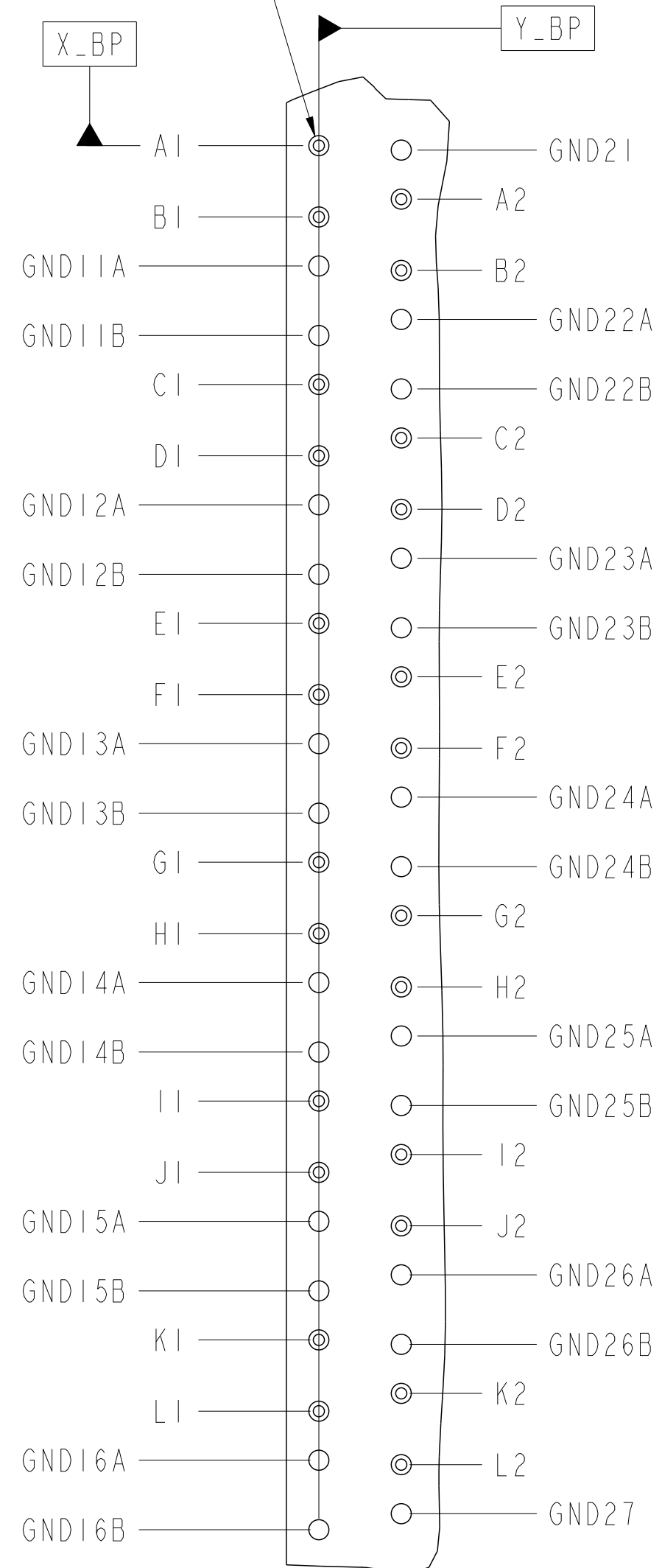

DETAIL A
SCALE 8:1

NOTES:

- CONNECTOR MATERIALS
SHROUD: HIGH-TEMP THERMOPLASTIC, GRAY, UL94V-0
CONTACTS: HIGH PERFORMANCE COPPER ALLOY
- CONTACT PLATING:

SEPARABLE INTERFACE: PERFORMANCE-BASED PLATING, QUALIFIED TO MEET THE REQUIREMENTS OF FCI PRODUCT SPECIFICATION GS-12-588, INCLUDING TELCORDIA GR-1217-CORE (NOVEMBER 1995) CENTRAL OFFICE (CO) OR UNCONTROLLED ENVIRONMENT (UE) TEST SEQUENCE AS NOTED IN P/N TREE.

PRESS-FIT TAILS: TIN OVER NICKEL, OR TIN-LEAD ALLOY OVER NICKEL. SEE P/N TREE.
- PRODUCT SPECIFICATION: GS-12-588
- APPLICATION SPECIFICATION: GS-20-121
- PRODUCT MARKING (PART NUMBER AND LOT CODE) ON THESE SURFACES.
- HOUSING MUST WITHSTAND EXPOSURE TO 260°C PEAK TEMPERATURE FOR 40 SECONDS IN A CONVECTION, INFRA-RED, OR VAPOR-PHASE REFLOW OVEN.
- PACKAGING MEETS GS-14-920 LEAD-FREE LABELING SPECIFICATION.
- NOTCH INDICATES "ROW A" SIDE OF CONNECTOR.
- SEE APPLICATION SPECIFICATION FOR ROUTING GUIDELINES, ADDITIONAL PTH GUIDELINES, MATED DIMENSIONS, GUIDE PN SELECTION, ETC.
- SCREW IS OPTIONAL AND ENGAGES WITH BOTTOM OF GUIDE-PIN FROM BENEATH THE PCB FOR ADDITIONAL GUIDE-PIN SUPPORT.
- OPTIONAL HOLE LOCATION FOR GROUNDED PIN OR ADDITIONAL GUIDE-PIN SUPPORT. SEE TABLE 1 ON SHEET 1 FOR ADDITIONAL DETAILS.
- \triangle TAIL LENGTH=1.3mm FOR Ø0.55[0.0217"]COMPLIANT PIN DRILL
TAIL LENGTH=1.5mm FOR Ø0.45[0.0177"]COMPLIANT PIN DRILL
- A \triangle SYMBOL WILL BE NEXT TO ANY DIMENSION, VIEW OR NOTE THAT HAS BEEN MODIFIED WITH THE CURRENT DRAWING REVISION.



Copyright FCI.

spec ref	SEE NOTES	dr	Kok-Hoe Lee	2010/06/23	projection	MM	size	A2	scale	4:1					
tolerance std	TOLERANCES UNLESS OTHERWISE SPECIFIED	eng	Sandar Soe	2014/10/02			ecn no	ELX-S-18843-1	rel level	Released					
ASME Y14.5		chr	-	2014/12/10							product family	XCede			
		appr	Chen-Hong Tan												
surface	linear	0.X	±0.2		MODULE ASSEMBLY VERTICAL HEADER, 6-COLUMN, 6-PAIR	title	no 10104997	rev E	ASME Y14.5	angular 0° ±					
		0.XX	±0.10								www.fci.com	cat. no.	SEE P/N TREE	Product - Customer Drw	sheet 8 of 8
		0.XXX	±0.050												

PDS: Rev :E

STATUS:Released

Printed: Dec 10, 2014